

Packaging Information / Reference Pattern Layout Dimensions

● SOT-25J

Unit: mm

■ Packaging Information

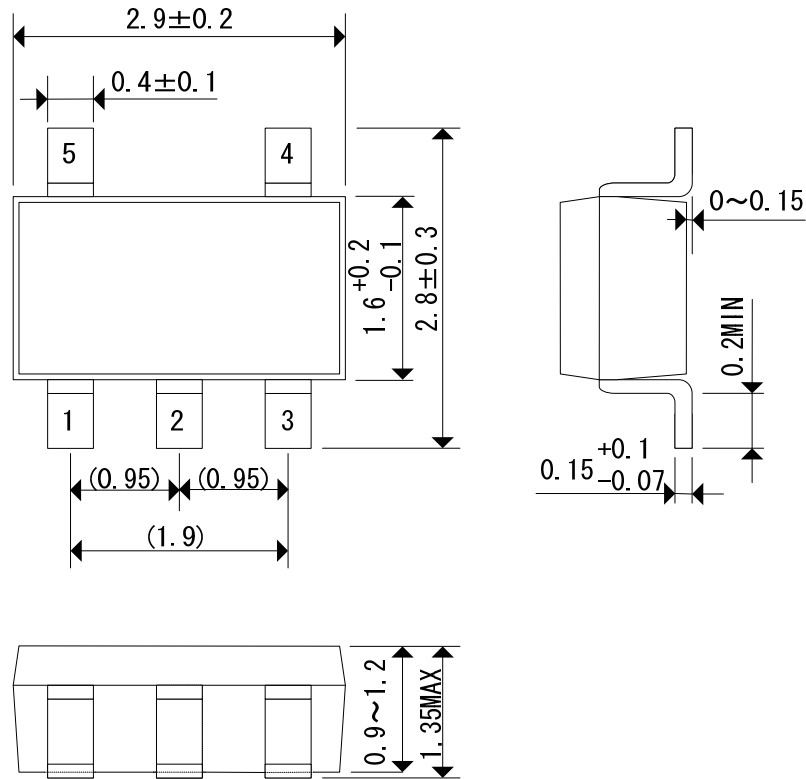

■ Reference Pattern Layout Dimension

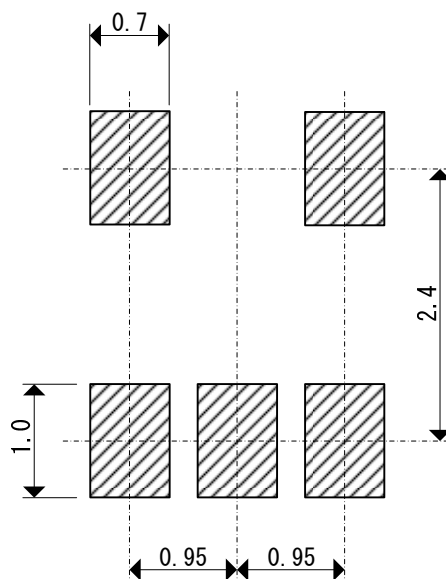

Taping Specifications

● SOT-25J

■ Reel

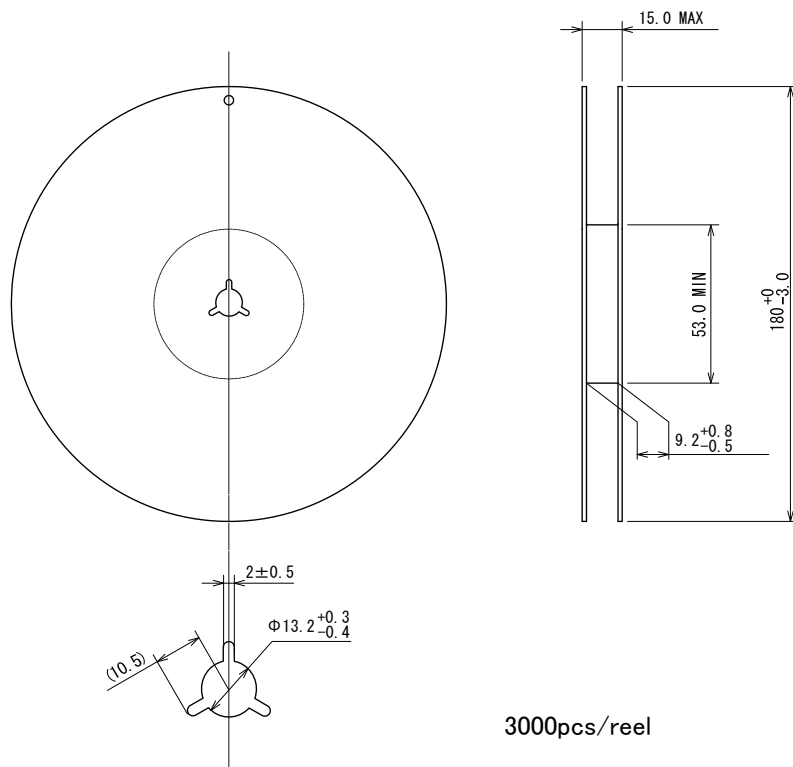

Unit: mm

■ Taping Specifications

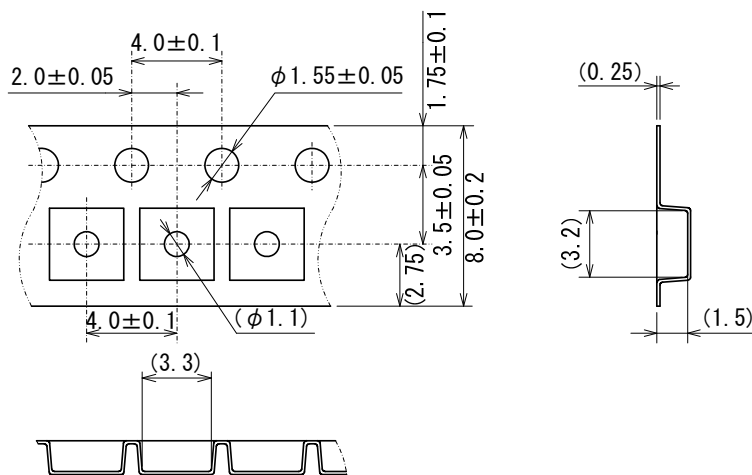

direction of feed
→

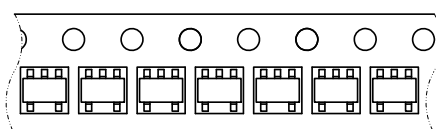

R Type : [Device orientation : Right]

Standard feed

● **SOT-25J Power Dissipation**

Power dissipation data for the SOT-25J is shown in this page.
 The value of power dissipation varies with the mount board conditions.
 Please use this data as one of reference data taken in the described condition.

1. Measurement Condition (Reference data)

- Condition: Mount on a board
- Ambient: Natural convection
- Soldering: Lead (Pb) free
- Board: Dimensions 40 x 40 mm (1600mm² in one side)
 Copper (Cu) traces occupy 50% of the board area
 In top and back faces
 Package heat-sink is tied to the copper traces
- Material: Glass Epoxy (FR-4)
- Thickness: 1.6 mm
- Through-hole: 4 x 0.8 Diameter

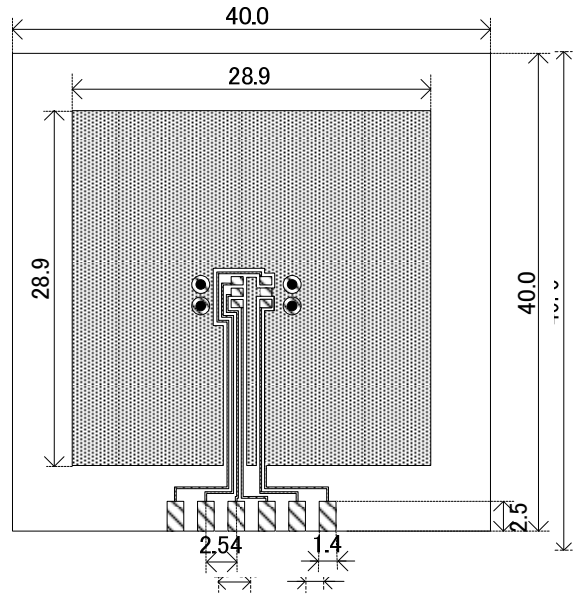

Evaluation Board (Unit: mm)

2. Power Dissipation vs. Ambient Temperature

Board Mount (T_{imax}=125°C)

Ambient Temperature (°C)	Power Dissipation Pd (mW)	Thermal Resistance (°C/W)
25	500	200.00
85	200	

